

7 ft. 6 in.
BELOW GROUND
FIBERGLASS LIFT STATION
INSTALLATION MANUAL

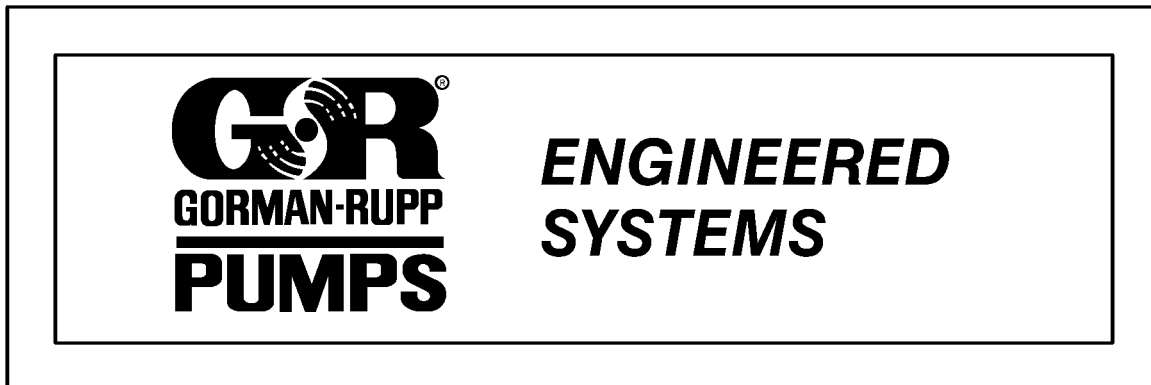

THE GORMAN-RUPP COMPANY • MANSFIELD, OHIO

www.gormanrupp.com

GORMAN-RUPP OF CANADA LIMITED • ST. THOMAS, ONTARIO, CANADA

Printed in U.S.A.

©Copyright by the Gorman-Rupp Company

7 ft. 6 in. BELOW-GROUND FIBERGLASS LIFT STATION INSTALLATION INSTRUCTIONS

INTRODUCTION

This document provides important information for personnel responsible for the installation of your Gorman-Rupp lift station.

This station has been operated and thoroughly tested at the factory to ensure that it meets your pumping requirements and is ready for installation.

Please read this manual completely before installing the station. If the procedures in this manual are followed carefully, your Gorman-Rupp lift station will provide years of continuous service.

This manual covers the basic lift station. Your station may include equipment not covered in these instructions. All phases of the installation should be in compliance with applicable codes and performed in a workmanlike manner.

The driver of the truck delivering the lift station will have an Operation and Maintenance Manual for

the specific station. This manual will be helpful in installing the lift station.

If there are any questions regarding the pump station which are not covered in this manual or in other literature accompanying the unit, please contact the Gorman-Rupp Company:

The Gorman-Rupp Company
P.O. Box 1217
Mansfield, Ohio 44901-1217
Phone: (419) 755-1011

WARRANTY INFORMATION

The warranty provided with your pump station is part of Gorman-Rupp's support program for customers who install, operate and maintain their equipment as described in this and the other accompanying literature. Please note that should the equipment be abused, damaged or modified to change its performance beyond the original factory specifications, the warranty will become void and any claim will be denied.

The following are used to alert personnel to procedures which require special attention, to those which could damage equipment, and to those which could be dangerous to personnel:



Immediate hazards which WILL result in severe personal injury or death. These instructions describe the procedure required and the injury which will result from failure to follow the procedure.



Hazards or unsafe practices which COULD result in severe personal injury or death. These instructions describe the procedure required and the injury which could result from failure to follow the procedure.



Hazards or unsafe practices which COULD result in minor personal injury or product or property damage. These instructions describe the requirements and the possible damage which could result from failure to follow the procedure.

NOTE

Instructions to aid in installation, operation, and maintenance or which clarify a procedure.

CONTENTS

SAFETY PAGE 2

SITE PREPARATION PAGE 3

 Electrical PAGE 3

 Pad Preparation PAGE 3

 Piping PAGE 3

 Lifting Equipment PAGE 3

PREINSTALLATION INSPECTION PAGE 3

OFF-LOADING PAGE 4

TEMPORARY STORAGE PAGE 4

STATION MOUNTING PAGE 5

PIPING INSTALLATION PAGE 5

 Suction and Discharge Piping PAGE 6

 Water Hammer Arrestor PAGE 7

BACKFILLING PAGE 7

AUXILIARY SERVICE CONNECTION PAGE 7

ENTRANCE TUBE ASSEMBLY PAGE 8

ELECTRICAL SERVICE CONNECTION PAGE 8

FINAL INSTALLATION INSPECTION PAGE 9

ILLUSTRATIONS

 Figure 1. Mechanical Joint bell Bolt Tightening Sequence PAGE 6

 Figure 2. Lifting Station With Sling and Spreader Bar PAGE 10

 Figure 3. Foundation Plan PAGE 11

 Figure 4. Suction Line Configuration PAGE 12

 Figure 5. Piping Supports PAGE 13

 Figure 6. Typical Installation PAGE 14

SAFETY

This information applies to the Gorman-Rupp Below-Ground Fiberglass Lift Station covered in this manual.



The electrical power used to operate this station is high enough to cause injury or death. Obtain the services of a qualified electrician to make all electrical connections.



Install and operate this station in accordance with the National Electrical Code and all local codes. Ground the unit before applying line potential. Failure to

follow the instructions in this warning and manual could result in injury or death to personnel.



The electrical power to operate the equipment in this station is high enough to cause injury or death. Shut down incoming power and tag and lock all controls to prevent accidental startup during maintenance or repair of the equipment. The equipment in this station utilizes more than one source of power and therefore more than one disconnect may be required to completely de-energize all equipment being serviced.

The equipment in this station is designed for automatic control and can start without warning unless all circuits are de-energized. Failure to shut down and lock out power can result in death,

serious personal injury or damage to the equipment.

SITE PREPARATION

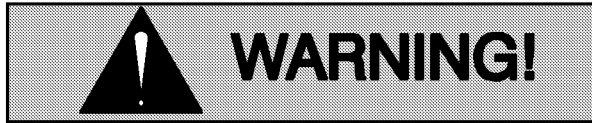

In the event of conflict between the instructions contained in this section and The National Electrical Code or local codes, The National Electrical Code or local codes shall take precedence.

Electrical

Notify the local power company in advance to assure that electrical power will be provided to the site before arrival of the lift station. Verify that incoming service is in conformance with design specifications on the electrical wiring diagram, $\pm 10\%$.

Pad Preparation

It is recommended that construction of the wet well and lift station pad be completed before the station arrives. If this work has not been completed, or if the station will not be installed immediately, it should remain sealed as shipped from the factory.

Verify that the lift station pad and wet well conform to design specifications. Verify that 8 anchor bolts have been properly located in the pad (see Figure 3).

Remove all construction debris from the wet well, piping and manholes. If debris is not removed, stoppages will occur and could result in damage to pumps and valves. Lift station collection lines flowing to the wet well should be flushed and debris removed.

NOTE

Local soil and ground water conditions affect the amount of concrete required in the station pad to prevent flotation of the station; this must be determined by the engineer. Refer to the station specifications for the buoyancy factor.

Remove all foreign material from the lift station pad. Ensure that the pad is smooth and level.

To eliminate point loading and damage to the fiberglass, use a notched trowel to completely coat the pad area with asphalt cement. This coating **must** extend 6 inches (152 mm) beyond the diameter of the station base flange.

NOTE

A notched trowel and 10 gallons of asphalt cement were provided with the lift station. In cold weather, the cement should be stored for 24 hours at 70° F (21° C) or above to facilitate application.

Piping

It is recommended that the influent piping and the force main discharge line be installed before arrival of the pump station. All wet well piping must be firmly supported and there must be no mechanical loads transferred to the pump station.

Lifting Equipment

Arrange to have proper unloading equipment available upon arrival of the station.

Lifting equipment must include a spreader bar and a four (4) point sling system of sufficient strength. The spreader bar must be a minimum of 11 feet (3.4 m) long, and each sling must be a minimum of 9 feet (2.7 m) long. To avoid damage to the fiberglass, do not allow lifting cables to contact the station (see Figure 2). **The overall weight of the lift station will not exceed 15,000 lbs. (6804 kg.).** Slings and lifting equipment must be rated for at least the load of the station **plus a minimum safety factor of 4 times the weight of the station.**

PREINSTALLATION INSPECTION

The lift station was thoroughly inspected before leaving the factory and was complete and operational when shipped. Loading and tie down were supervised by Gorman-Rupp personnel and the bed of the carrier was padded, if necessary, to protect the station. In spite of all precautions however, damage to the station may have occurred in transit and the station should be inspected before being off-loaded.

Before unloading, make a thorough check to assure that the station has not been damaged during transit.

OFF-LOADING

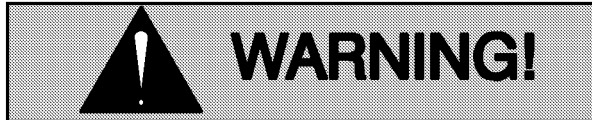

Make certain that the lifting equipment and sling are of an adequate capacity, plus an appropriate safety factor (a minimum of 4 times the weight of the station), to support the weight of the station.

Do not push or slide the station off the truck bed. Each station contains a control panel with sensitive electrical components. Avoid rough handling, and use caution to prevent undue shock and vibration to the station.

If possible, position the lifting equipment so that the station can be lifted and set on the station pad without moving the lifting equipment. Make certain that the lifting equipment is on a solid surface and stabilizers are in position.

Check that the angle of lift will not de-rate the lifting equipment below the required capacity.



Do not attempt to lift the station with cables making contact with the station. Serious damage to the station could result.



When the pump station is suspended, keep personnel from beneath it at all times.

Make all lifts as smoothly as possible. The station equipment includes control panels with sensitive electrical components, and care should be taken to avoid shocks and rough handling.



The station enclosure is equipped with four (4) lifting eyes attached to the supports in the station floor. Use **only** the four (4) lifting eyes to lift the enclosure. Failure to do so may result in serious damage to the station equipment.

Lower the lift station onto the concrete pad using a four (4) point sling and spreader bar (see Figure 2).



Do not use blocks or shims between the lift station base and concrete pad. The lift station is designed for proper internal drainage only when the station base is level on the pad.

Ensure that the lift station suction line bell is facing the wet well.

After the station has been lowered onto the pad, do not remove the sling until the positions of the piping holes have been checked for alignment; repeat short lifts as often as necessary until these features are aligned.

When the station is properly seated on the pad, remove the slings, using caution not to damage the fiberglass enclosure.

TEMPORARY STORAGE



If the station is to be stored for an extended period of time before installation, or if it is to be installed without being put into operation for an extended period of time, temporary power must be applied to the control system to prevent damage.

If the station will not be installed on the pad immediately, place the station on a level surface of smooth, clean planks or similar support. **Do not** place the station on uneven or rocky terrain. Ensure that the

site is high enough to keep the station above ground water level. **Make sure** the station is protected against vandalism during storage.



All electrical equipment in the pump station is grounded to the control panel sub-plate. Before applying line potential, connect the main ground lug terminal on the sub-plate in the pump station control panel to a driven earth ground according to the National Electrical Code and all local codes. Failure to do so can result in serious personal injury or death.



Temporary power must be 60 Hz. single phase and cannot exceed 115 volts, $\pm 10\%$. Severe damage to the station electrical circuits can result if voltage exceeds design conditions.

Connect 60 Hz., 115-volt, single phase service to the control center in accordance with the schematic circuit diagram located in this manual.

Place the blower and/or heater into operation.

Replace the shipping cover on the entrance flange. Be certain that the sealant is in place and the cover is water-tight.

STATION MOUNTING

Using the plates, nuts and spacers provided, secure the station base flange to the stainless steel anchor bolts previously installed in the concrete pad.



The station must be anchored securely to prevent flotation. Stainless steel anchor bolts, plates and nuts have been supplied,

and **must** be used to ensure against possible station flotation.

PIPING INSTALLATION



All regulations established by the Occupational Safety and Health Administration (OSHA) for confined spaces must be followed when working on the wet well and/or piping. Failure to do so could result in serious injury or death to personnel.



Automatic control features of the system can cause the pumps to start without warning. If line potential has been applied to the pump station, make certain that the main service disconnect is locked in the OFF position before working on the system piping. If no main service entrance disconnect has been installed, make certain that all circuits on the control panel are locked open.

When working with liquids that produce hazardous fumes, make certain that the wet well is adequately ventilated and/or protective breathing apparatus is worn. Protective clothing must always be worn.



Do not allow any unprotected part of the body to come into contact with liquids being pumped; serious illness or disease could result. Clean tools and protective clothing after exposure. Gases present in wet wells may be extremely hazardous; to not work in an unventilated area without protective breathing apparatus.

Clean debris from the wet well before and after piping installation. Debris can cause pump and/or

valve damage. Flush pump station collection lines flowing into the wet well and remove any debris.



Damage to the pump or valves resulting from debris in the suction line will not be covered under warranty.

Carefully check the wet well and piping and remove all debris, including construction debris such as nuts, bolts, wire, weld slag, and other foreign material. Flush pump station collection lines flowing into the wet well before connecting the suction and discharge piping to prevent debris from entering the pump.

Suction and Discharge Piping

Station suction and discharge lines terminate outside the station walls with mechanical joint bells. Transition through the station wall is made with Class 53 ductile iron pipe. Install the suction line and force main to the wet well in accordance with the engineer's plans and specifications.

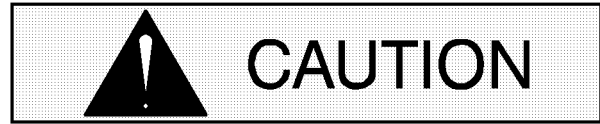

Use caution to avoid damaging the fiberglass bell during installation. Do not use impact wrenches. Ensure that no stress is applied to the bell during piping connection. Torque the attaching hardware as indicated in Figure 1.

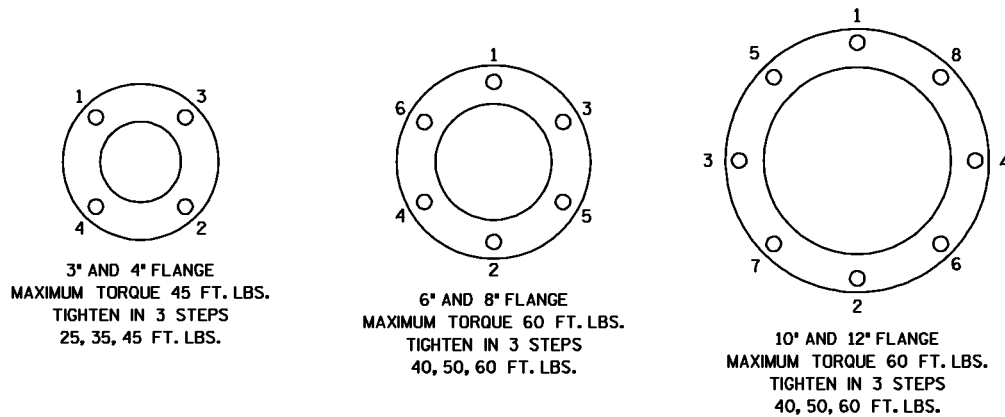

Figure 1. Mechanical Joint Bell Bolt Tightening Sequence



Limit the horizontal length of suction lines to the wet well. Suction lines must slope downward to the wet well from the station (see Figure 4).

To avoid transfer of piping loads to the pump station, the suction and discharge lines must be supported. Supports should consist of either concrete blocks or pillars between the piping bells and the pad. Supports must be anchored securely to prevent dislocation during backfill operations (see Figure 5).

To eliminate pipe strain and stresses due to soil condition or due to changes in flow direction, the

force main piping will require thrust blocks. Size, style and placement of thrust blocks should be as indicated by the engineer's plans and specifications.

If a pressure test of the force main is to be performed, the lift station must be isolated. The 3-way valve in the station will provide dead tight shutoff of 35 psi (2,5 kg/cm²) maximum. Failure to isolate the lift station may cause pump damage and station flooding.

NOTE

Flange adaptor bolts may loosen during shipping. Before start-up of the unit, check adaptor bolts and retighten if necessary. Flange adaptors are located on the suction and discharge lines on the interior of the lift station just before the lines exit the station wall.

Water Hammer Arrestor

In installations where the length, rise or profile of the force main may cause destructive hydraulic shock, a Water Hammer Arrestor should have been specified. The device will control these concussions and prevent the rupturing of pumps, valves or piping.

If a Water Hammer Arrestor has been specified, make certain that it is installed and functioning properly before the lift station is placed in operation.

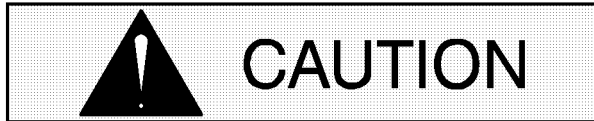

Air release lines or valves furnished with the lift station **are not** designed to act as shock arrestors, and are not intended as substitutions for proper control devices.

BACKFILLING

Backfill a minimum of 18 inches (457 mm) around the station and entrance tube (see Figure 6) with a naturally-rounded material that, when poured, becomes interlocked and exhibits sufficient resistance to shear and load bearing capacities to be termed "self-compacting". The material answering this requirement is a naturally-rounded, clean and free-flowing aggregate of 1/4-inch (6 mm) nominal size (ranging from 1/8-inch (3 mm) to 3/8-inch (9 mm) in diameter, with 100% passing through a 3/8-inch screen, and 0-10% passing through a number 10 screen. Local names include "pea gravel", "pea stone" and "roofing gravel".



Backfill must be free of rocks, debris and frozen sections. **Do not** use shale, clay, slag, cinders, loams, silts, stone screenings, stone dust, shells or soft limestone.

If another material is used to fill to grade level, polyethylene film or a suitable substitute must be used to cover the backfill material listed above.

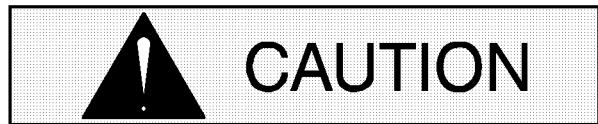

If a concrete pad is installed above the lift station at grade level, care must be taken to avoid contact of the pad and the lift station dome or entrance tube. Severe structural damage may result.

AUXILIARY SERVICE CONNECTION

Pipe sizes in the auxiliary service module are as follows:

Sump Pump Discharge . . .	1-1/4-inch PVC
Air Release (3)	1-1/4-inch PVC
Air Bubbler (If Req'd)	3/8-inch PVC
Module Casing	6-inch mechanical joint Class 53 Ductile Iron

Extend pipes through the wet well wall from the mechanical joint at the lift station. Use PVC, galvanized, or stainless steel pipe to make extensions.

Pipes must be encased in 6-inch (152 mm) cast iron pipe extending from the mechanical joint connection at the lift station through the wall of the wet well (see Figure 6).

NOTE

Pipes and casing must slope at least 2° – 3° downward to the wet well from the lift station.

Air release and sump pump discharge lines should extend approximately 12 inches (305 mm) inside the wet well, and terminate with a 45° elbow directed toward the wet well wall.

NOTE

If controls are furnished by Gorman-Rupp, refer to the separate electrical details provided for liquid level control system installation.

If used, the air bubbler pipe should extend into the center of the wet well and terminate with a tee fitting. Where possible, position the tee fitting so that the cleanout extension will be accessible from the manhole cover or inspection hatch.

Extend the cleanout extension pipe from the tee fitting to the manhole cover and cap the pipe tightly.

Connect the bubbler pipe (if used) to the tee fitting. Connect the air bell to the bubbler pipe. Refer to the engineer's plans and specifications to determine the proper distance between the air bell and the floor of the wet well.

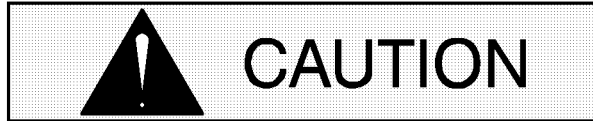

The air bubbler pipe and cleanout extension must be firmly supported and **absolutely airtight**.

The service module cast iron pipe should extend into the wet well approximately 3 inches (76 mm). Seal the end of the pipe by working grouting cement around the auxiliary discharge pipes. Recommended grouting cement is as follows:

Embecco® – Manufactured by:
Master Builders Division
2490 Lee Boulevard
Cleveland, Ohio 44118

Seal the clearance between the module casing pipe and the wet well wall with grouting cement.

Erect a concrete or cement block pillar between the lift station and the wet well to support auxiliary service pipe.

ENTRANCE TUBE ASSEMBLY



Water-tight connection of the entrance tube is imperative to prevent seepage into the lift station.

The following components are shipped inside the station for attaching the entrance tube to the top of the station.

- 1) Caulking gun
- 2) Two tubes of caulking material for each entrance tube connection

- 3) 16 sets of stainless steel nuts, bolts, and cadmium plated washers for each entrance tube connection.

Clean the entrance tube flange. Run four 5/16-inch (8 mm) beads of caulking compound around the face of the entrance tube flange – two inside and two outside of the bolt hole centerline. Beads should be continuous, unbroken, and overlapped at the ends to ensure a water-tight seal. Run a short bead between each bolt hole to form a continuous bead around the hole.

Lift the entrance tube using the lifting eyes provided. Clean all loose and foreign material from the lower flange face. Set the tube in place, and check the alignment of the air ducts, conduits and ladder rails. Make the air duct and conduit connections between the entrance tube and the station with the couplings provided.

Install all nuts, bolts and washers supplied with the station. Washers must be used under both the bolt heads and nuts.

If the station has more than one section of tube, repeat the steps above.



To eliminate the possibility of station flooding, do not leave the excavation until all sections of tube have been installed.

ELECTRICAL SERVICE CONNECTION



The electrical power applied to this station is high enough to cause injury or death. Ground the station before applying line potential. Failure to do so may result in injury or death. A grounding electrode system must be available or installed and connected according to the National Electrical Code or local codes. Grounding electrodes are not furnished with this lift station.

This equipment contains more than one source of power. More than one discon-

nect is required to completely de-energize the lift station.

Contact the electrical contractor for service extension to the control panel. Wiring must be made in accordance with the plans and specifications per local and the National Electrical Code. The schematic wiring diagram furnished with the station must be followed in making connections to the control panel.



On installations where a low voltage (115 volts) tap on incoming service is specified for control circuits and auxiliary equipment, care must be taken to ensure that the tap is not made to high voltage lines. If this occurs, **severe damage to control circuits will result.** The upper voltage limit for control power is 126 volts.

All electrical equipment in the lift station is grounded to the control panel sub-plate at the factory. Before applying line potential, however, ground the control panel itself at the main ground lug terminal installed on the control panel sub-plate.

The grounded circuit conductor, or one of the transformer secondary conductors (if supplied), is to be grounded if conditions permit. Follow practices recommended in the National Electrical Code or local codes.

Terminal blocks are provided for the power connections to the lift station. Refer to the schematic wiring diagram furnished with the station.

If a remote warning and/or alarm device is to be installed outside the lift station housing, install and connect the device.

Connect the earth ground to the main lug.

FINAL INSTALLATION INSPECTION

Verify that all valves in the lift station are in the closed position as shipped from the factory.

Verify that electrical service is properly connected.

Verify that, where specified, a Water Hammer Arrestor and thrust blocks are installed, and that all pipes connected to the station are supported with pillars.

Clean all construction debris from the wet well and suction pipe intakes.



Lifting ring is provided for removal and replacement of station. All four eyes **must** be used. **Approximate station weight - 15,000 lbs. (6804 kg).**

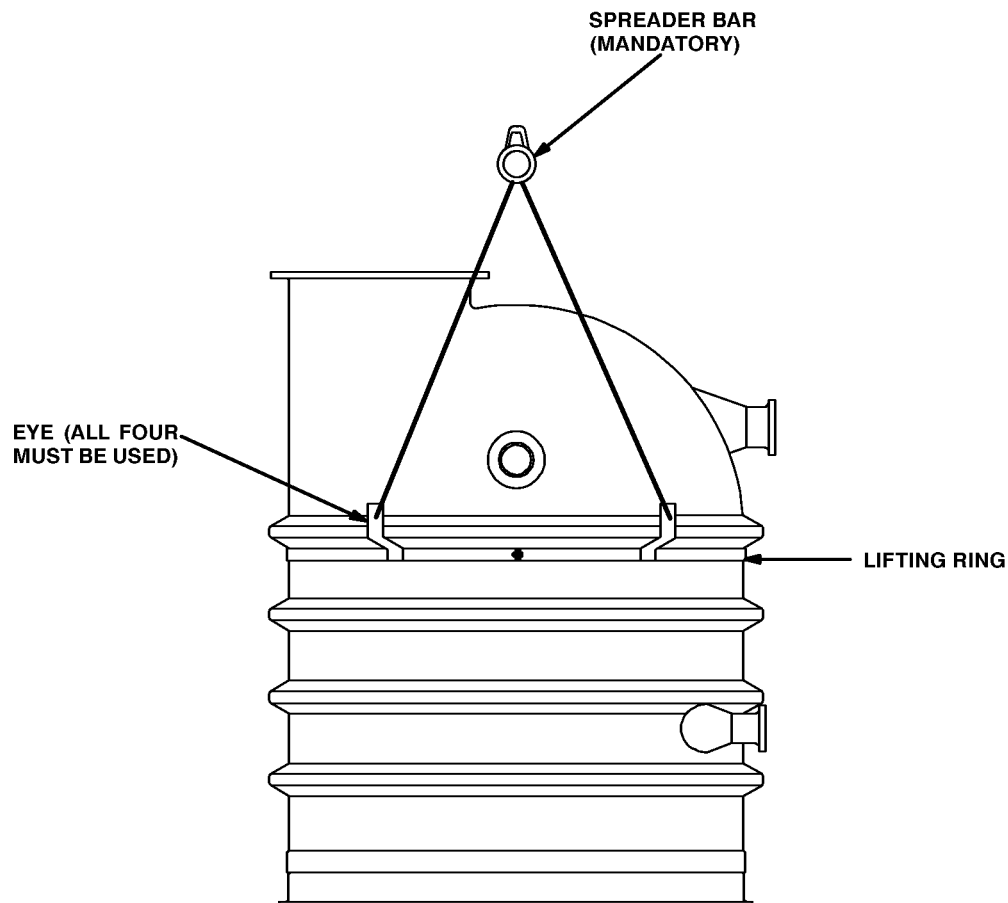

NOTE

Avoid sudden starts and stops while moving station.

Figure 2. Lifting Station With Sling and Spreader Bar

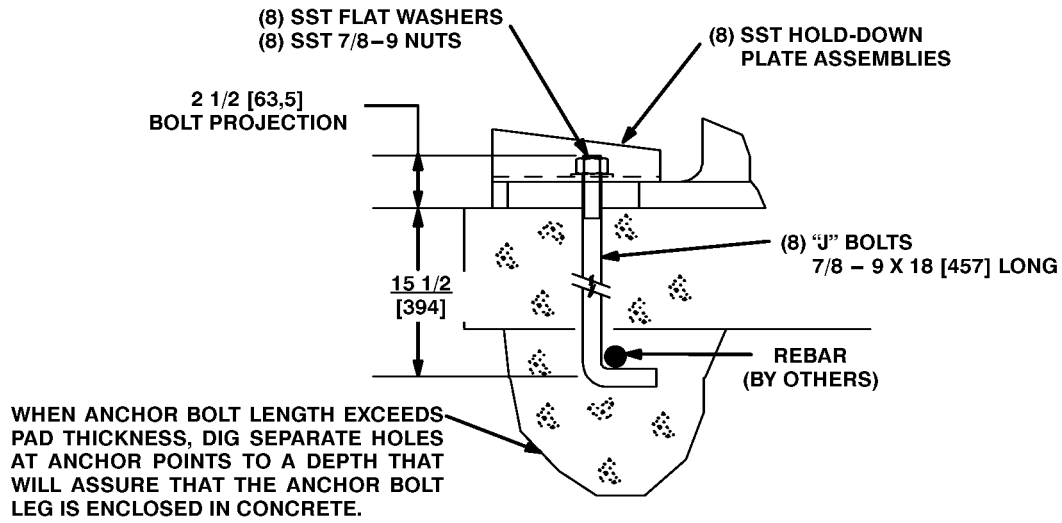

ANCHOR BOLT INSTALLATION

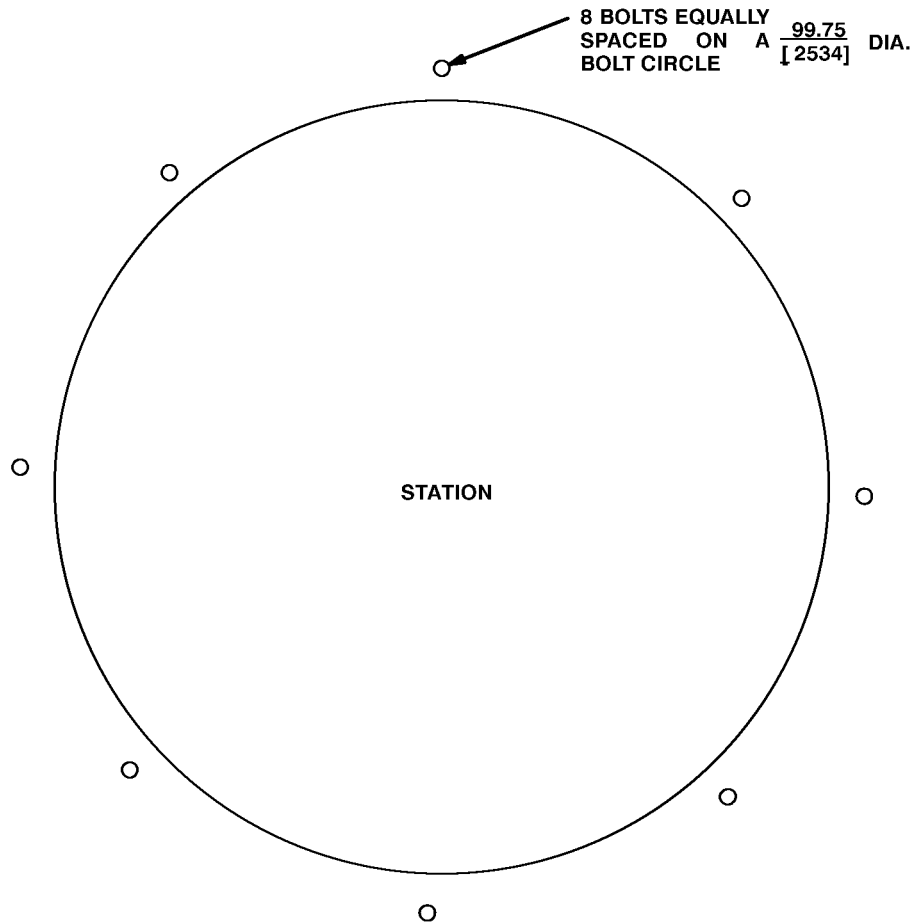

DIMENSIONS:
INCHES
[MILLIMETERS]

ANCHOR BOLT LOCATIONS

Figure 3. Foundation Plan

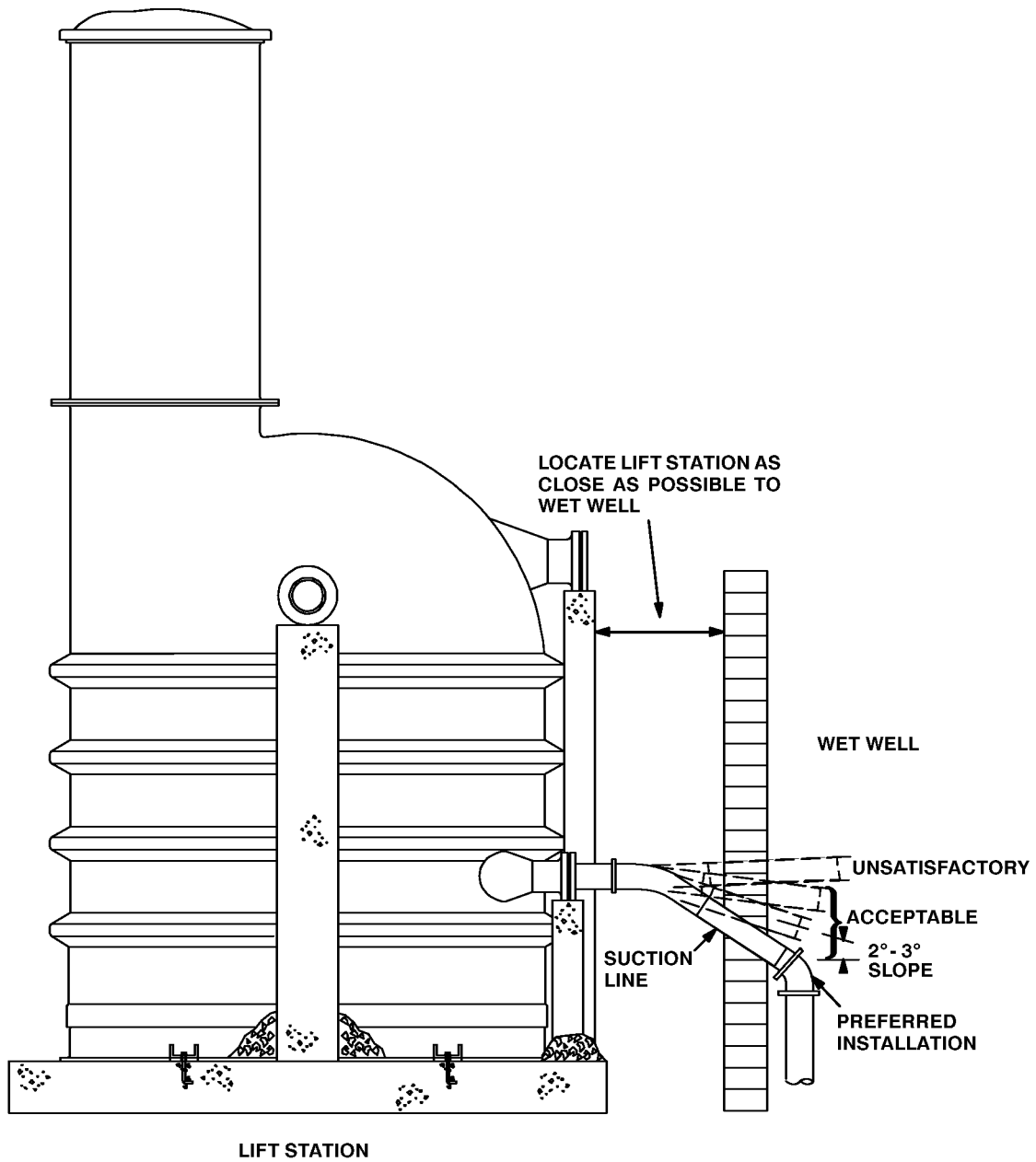
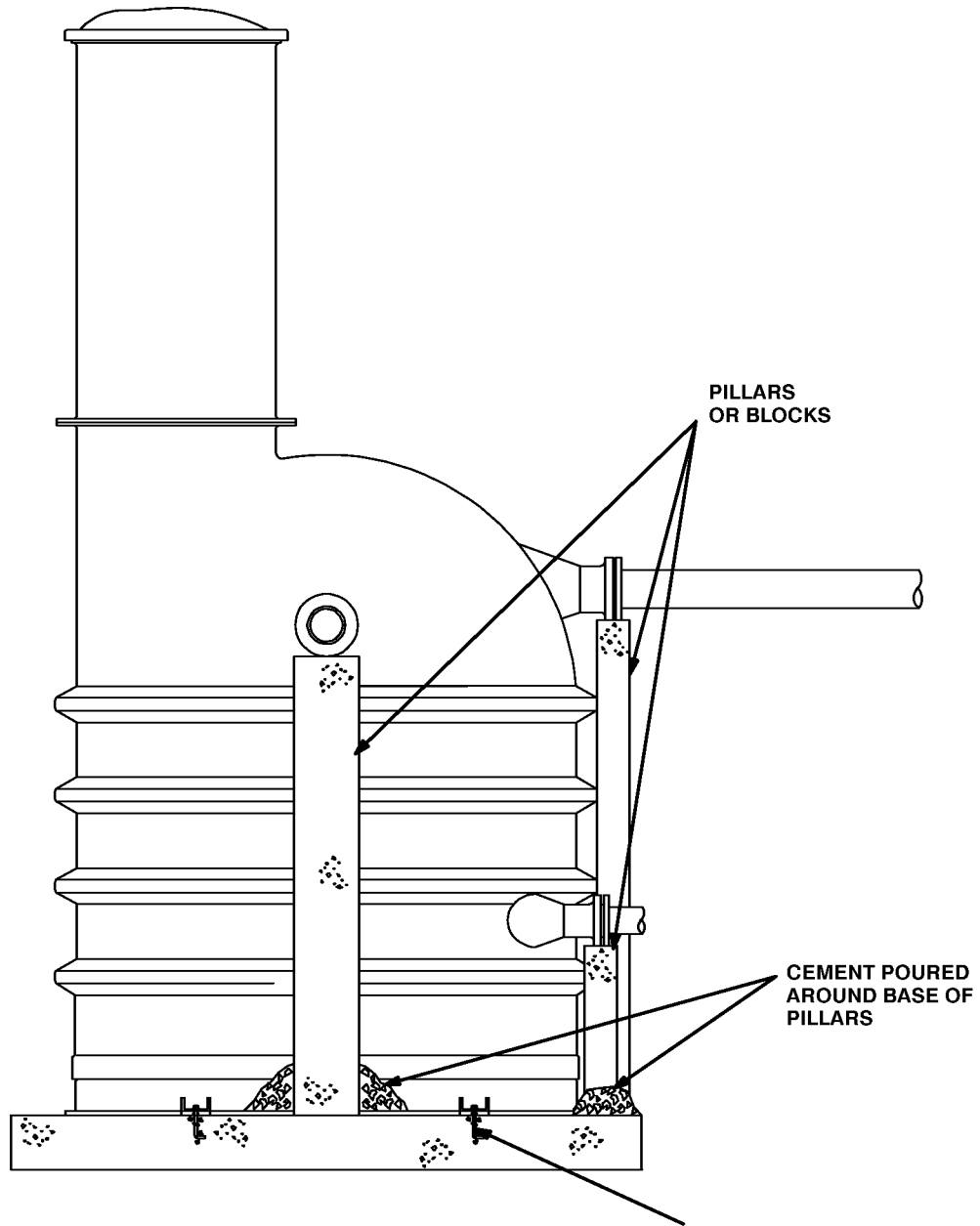

Figure 4. Suction Line Configuration



PILLARS
OR BLOCKS

CEMENT POURED
AROUND BASE OF
PILLARS

NOTE

When anchor bolt length exceeds pad thickness, dig separate holes at anchor points deep enough to ensure bolt legs are enclosed in concrete.

Figure 5. Piping Supports

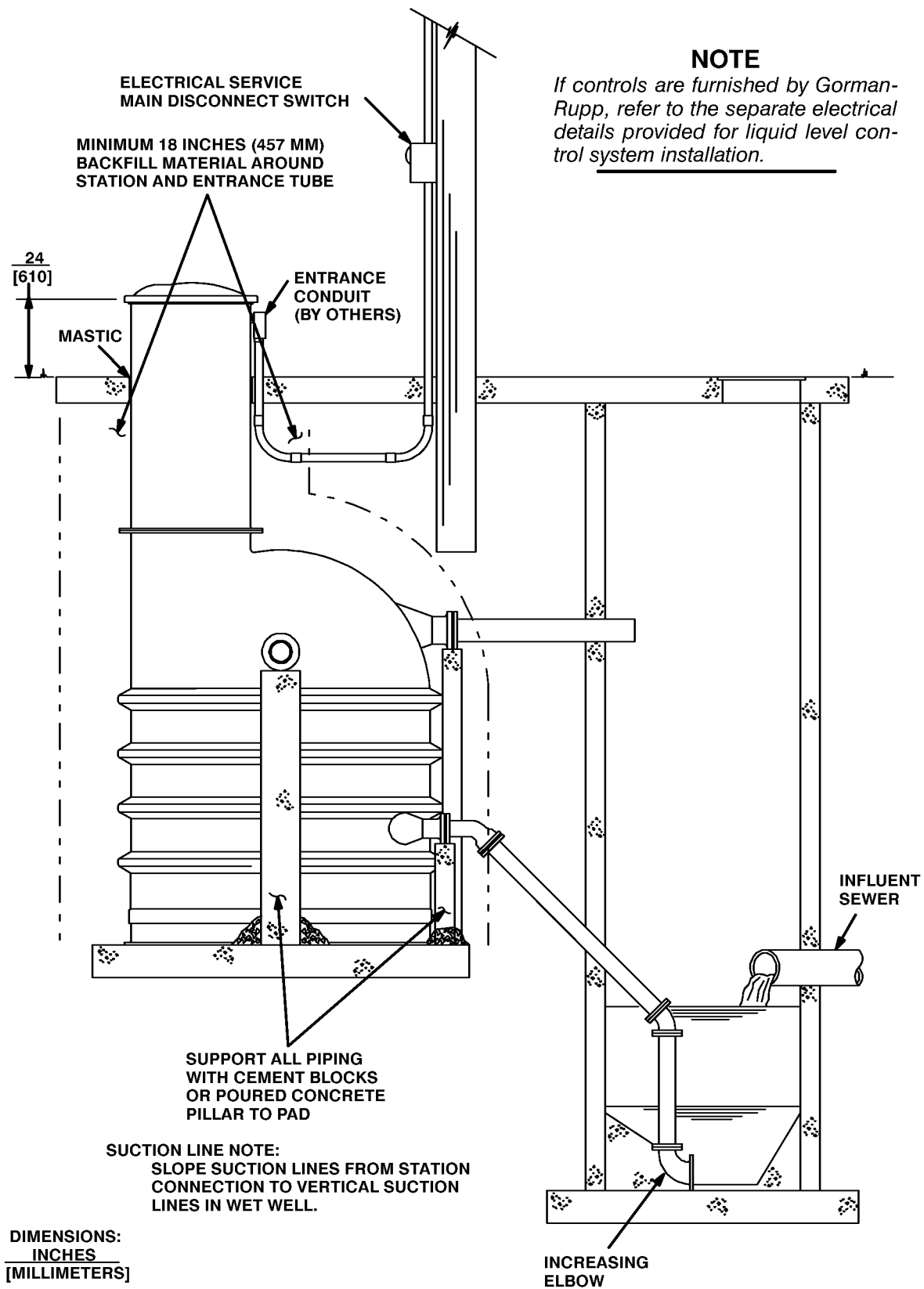

Figure 6. Typical Installation



THE GORMAN-RUPP COMPANY • MANSFIELD, OHIO

www.grpumps.com

GORMAN-RUPP OF CANADA LIMITED • ST. THOMAS, ONTARIO, CANADA

Printed in U.S.A.

©Copyright by the Gorman-Rupp Company