

# DUPLEX LIFT STATION LESS ENCLOSURE INSTALLATION MANUAL

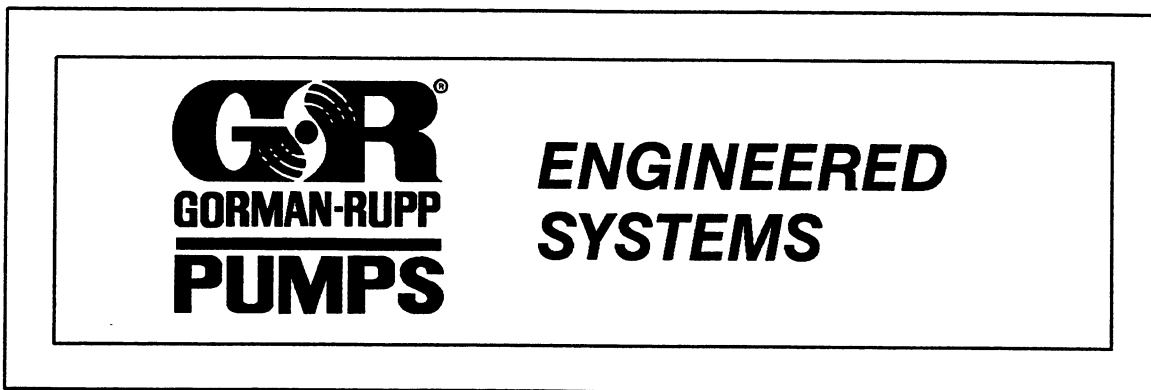

**THE GORMAN-RUPP COMPANY • MANSFIELD, OHIO**

GORMAN-RUPP OF CANADA LIMITED • ST. THOMAS, ONTARIO, CANADA Printed in U.S.A.

©Copyright by the Gorman-Rupp Company



# DUPLEX LIFT STATION LESS ENCLOSURE INSTALLATION INSTRUCTIONS

## Introduction

This document provides important information for personnel responsible for the installation of your Gorman-Rupp lift station.

This station has been operated and thoroughly tested at the factory to ensure that it meets your pumping requirements and is ready for installation.

Please read this manual completely before installing the station. If the procedures in this manual are followed carefully, your Gorman-Rupp lift station will provide years of continuous service.

This manual covers the basic lift station. Your station may include equipment not covered in these instructions. All phases of the installation should be

The following are used to alert personnel to procedures which require special attention, to those which could damage equipment, and to those which could be dangerous to personnel:



**Immediate hazards which WILL result in severe personal injury or death. These instructions describe the procedure required and the injury which will result from failure to follow the procedure.**



**Hazards or unsafe practices which COULD result in severe personal injury or death. These instructions describe the procedure required and the injury which could result from failure to follow the procedure.**

in compliance with applicable codes and performed in a workmanlike manner.

The driver of the truck delivering the station will have an Operation and Maintenance Manual for the specific station. This manual will be helpful in installing the station.

## WARRANTY INFORMATION

The warranty provided with your pump station is part of Gorman-Rupp's support program for customers who install, operate and maintain their equipment as described in this and the other accompanying literature. Please note that should the equipment be abused, damaged or modified to change its performance beyond the original factory specifications, the warranty will become void and any claim will be denied.

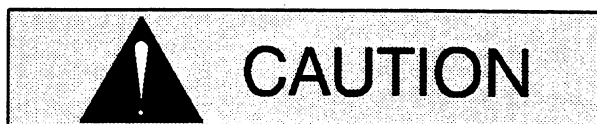

Hazards or unsafe practices which COULD result in minor personal injury or product or property damage. These instructions describe the requirements and the possible damage which could result from failure to follow the procedure.

## NOTE

*Instructions to aid in installation, operation, and maintenance or which clarify a procedure.*

**CONTENTS**

**SAFETY** ..... PAGE 2

**SITE PREPARATION** ..... PAGE 3

    Electrical ..... PAGE 3

    Pad Preparation ..... PAGE 3

    Lifting Equipment ..... PAGE 3

**PRE-INSTALLATION INSPECTION** ..... PAGE 3

**OFF-LOADING** ..... PAGE 3

**TEMPORARY STORAGE** ..... PAGE 4

**PIPING INSTALLATION** ..... PAGE 5

    Suction and Discharge Piping ..... PAGE 6

    Water Hammer Arrestor ..... PAGE 6

    Air Bubbler Liquid Level Control Lines ..... PAGE 7

**ELECTRICAL SERVICE CONNECTION** ..... PAGE 7

**FINAL INSTALLATION INSPECTION** ..... PAGE 7

**ILLUSTRATIONS**

    Figure 1. Anchor Hardware Installation ..... PAGE 4

    Figure 2. Lifting Station With Slings ..... PAGE 8

    Figure 3. Typical Installation ..... PAGE 9

**SAFETY**

This information applies to the Gorman-Rupp Duplex Lift Station covered in this manual.



The electrical power used to operate this station is high enough to cause injury or death. Obtain the services of a qualified electrician to make all electrical connections.



Install and operate this station in accordance with the National Electrical Code and all local codes. Ground the unit before applying line potential. Failure to follow the instructions in this warning and manual could result in injury or death to personnel.



The electrical power to operate the equipment in this station is high enough to cause injury or death. Shut down incoming power and tag and lock all controls to prevent accidental startup during maintenance or repair of the equipment. The equipment in this station utilizes more than one source of power and therefore more than one disconnect may be required to completely de-energize all equipment being serviced.

The equipment in this station is designed for automatic control and can start without warning unless all circuits are de-energized. Failure to shut down and lock out power can result in death, serious personal injury or damage to the equipment.

## SITE PREPARATION

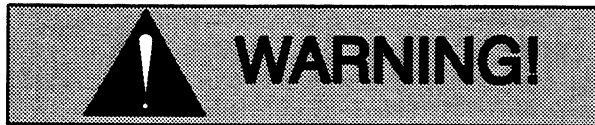

**In the event of conflict between the instructions contained in this section and The National Electrical Code or local codes, The National Electrical Code or local codes shall take precedence.**

### Electrical

Notify the local power company in advance to assure that electrical power will be provided to the site before arrival of the lift station. Verify that incoming service is in conformance with design specifications on the electrical wiring diagram,  $\pm 10\%$ . Where local codes permit, it is strongly recommended that power lines to the station terminate in a service entrance disconnect outside the station.

### Pad Preparation

It is recommended that construction of the wet well and lift station pad be completed before the station arrives. If this work has not been completed, or if the station will not be installed immediately, it should remain sealed as shipped from the factory.

The lift station pad and wet well must be constructed in accordance with design specifications. The pad should be fitted with anchor bolts and piping holes in accordance with the pad engineering drawing.

The mounting surface and surrounding area of the pad must be free of all foreign material and debris before the station is set in place. Even a small amount of debris on the pad can affect piping installation and station leveling.

Remove all construction debris from the wet well, piping and manholes. If debris is not removed, stoppages will occur and could result in damage to pumps and valves. Lift station collection lines flowing to the wet well should be flushed and debris removed.

### Lifting Equipment

Arrange to have proper unloading equipment available upon arrival of the station.

Lifting equipment must include a four (4) point sling system of sufficient strength and a minimum of 12 feet (3,7 m) long. **The overall weight of the lift station will not exceed 8,600 lbs. (3900 kg.).** Slings and lifting equipment must be rated for at least the load of the station plus a minimum safety factor of 4 times the weight of the station.

## PREINSTALLATION INSPECTION

The lift station was thoroughly inspected before leaving the factory and was complete and operational when shipped. Loading and tie down were supervised by Gorman-Rupp personnel and the bed of the carrier was padded, if necessary, to protect the station. In spite of all precautions however, damage to the station may have occurred in transit and the station should be inspected before being off-loaded.

Before unloading, make a thorough check to assure that the station has not been damaged during transit.

## OFF-LOADING

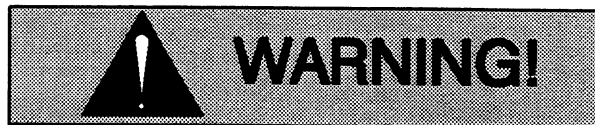

**Make certain that the lifting equipment and sling are of an adequate capacity, plus an appropriate safety factor (a minimum of 4 times the weight of the station), to support the weight of the station.**

**Do not push or slide the station off the truck bed.** Each station contains a control panel with sensitive electrical components. Avoid rough handling, and use caution to prevent undue shock and vibration to the station.

If possible, position the lifting equipment so that the station can be lifted and set on the pad without moving the lifting equipment. Make certain that the lifting equipment is on a solid surface and stabilizers are in position.

Check that the angle of lift will not de-rate the lifting equipment below the required capacity.



**When the pump station is suspended, keep personnel from beneath it at all times.**



The station base is equipped with lifting holes at each corner. Use **only** the four (4) lifting holes to lift the station. Failure to do so may result in serious damage to the station equipment.

Make all lifts as smoothly as possible. Lower the station onto the pad using a four (4) point sling system (see Figure 2).

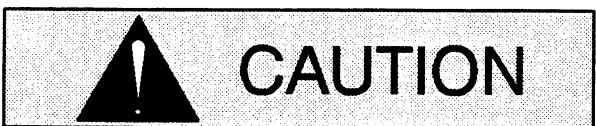

Do not use blocks or shims between the lift station base and the pad. The station is designed for proper installation only then the station base is level on the wet well.



**All regulations established by the Occupational Safety and Health Administration (OSHA) for confined spaces must be followed when working on the wet well and/or piping. Failure to do so could result in serious injury or death to personnel.**

When lowering the station onto the pad, extreme care must be taken not to damage the anchor bolts and/or any piping already installed above the level of the pad.

After the station has been lowered onto the pad, do not remove the sling until the positions of the anchor bolts and piping holes have been checked for alignment; repeat short lifts as often as necessary until these features are aligned.

After the station is properly seated on the pad, remove the slings, using caution not to damage the fiberglass enclosure.

To secure the station to the pad, place washers and nuts on each anchor bolt. Tighten the nuts securely, ensuring that at least two full threads of each anchor bolt shows above each nut (see Figure 1).

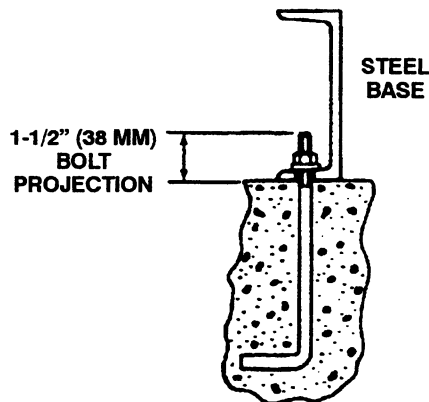
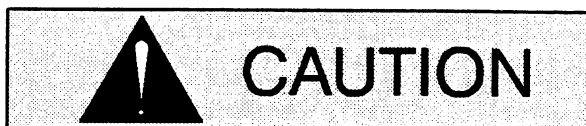

Figure 1. Anchor Hardware Installation

#### TEMPORARY STORAGE



If the station is to be stored for an extended period of time before installation, or if it is to be installed without being put into operation for an extended period of time, temporary power must be applied to the control system to prevent damage.

If the station will not be installed on the pad immediately, place the station on a level surface of smooth, clean planks or similar support. **Do not** place the station on uneven or rocky terrain. Ensure that the site is high enough to keep the station above ground water level. **Make sure** the station is protected against vandalism during storage.



**All electrical equipment in the pump station is grounded to the control panel sub-plate. Before applying line potential, connect the main ground lug terminal on the sub-plate in the pump station**

control panel to a driven earth ground according to the National Electrical Code and all local codes. Failure to do so can result in serious personal injury or death.

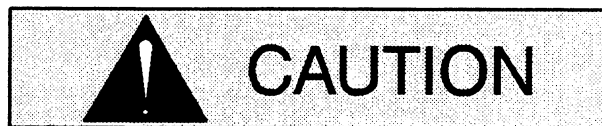

Temporary power must be 60 Hz. single phase and cannot exceed 115 volts,  $\pm$  10%. Severe damage to the station electrical circuits can result if voltage exceeds design conditions.

Connect 60 Hz., 115-volt, single phase service to the control center in accordance with the schematic circuit diagram provided with the station. Energize the pump station accessories as recommended in the pump station Operation and Service Manual.

## PIPING INSTALLATION



**All regulations established by the Occupational Safety and Health Administration (OSHA) for confined spaces must be followed when working on the wet well and/or piping. Failure to do so could result in serious injury or death to personnel.**



**Automatic control features of the system can cause the pumps to start without warning. If line potential has been applied to the pump station, make certain that the main service disconnect is locked in the OFF position before working on the system piping. If no main service entrance disconnect has been installed, make certain that all circuits on the control panel are locked open.**

When working with liquids that produce hazardous fumes, make certain that the wet well is adequately ventilated and/or protective breathing apparatus is worn. Protective clothing must always be worn.



**Do not allow any unprotected part of the body to come into contact with liquids being pumped; serious illness or disease could result. Clean tools and protective clothing after exposure. Gases present in wet wells may be extremely hazardous; do not work in an unventilated area without protective breathing apparatus.**

Clean debris from the wet well before and after piping installation. Debris can cause pump and/or valve damage. Flush pump station collection lines flowing into the wet well and remove any debris.

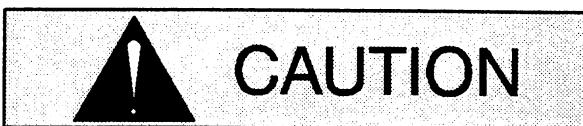

Damage to the pump or valves resulting from debris in the suction line will not be covered under warranty.

Carefully check the wet well and piping and remove all debris, including construction debris such as nuts, bolts, wire, weld slag, and other foreign material. Flush pump station collection lines flowing into the wet well before connecting the suction and discharge piping to prevent debris from entering the pump.

### Suction and Discharge Piping

Suction and discharge piping must be installed so that no mechanical load is placed on the pumps; the pump housing could be damaged from transferred mechanical loads. If these lines are not supported by the configuration of the wet well, they must be supported by concrete blocks, piers or both. Supports must be anchored securely to prevent dislocation during backfill operations.

To eliminate pipe strain and stresses due to soil condition or due to changes in flow direction, the force main piping will require thrust blocks. Size,

style and placement of thrust blocks should be as indicated by the engineer's plans and specifications.



Limit the horizontal length of suction lines to the wet well. Suction lines must slope downward to the wet well from the station (see Figure 3).

Suction lines should never slope down to the pump. Short horizontal runs can be tolerated if unavoidable, but ideally, suction lines should slope down from the pump a minimum of 2°. Suction lines must be air-tight to ensure efficient operation and priming and to avoid possible damage to the pump.

If an increasing elbow or other device is installed on the end of the suction line, make certain that it is cemented or otherwise firmly anchored in the wet well.

If a pressure test of the force main is to be performed, the lift station must be isolated. The 3-way valve in the station will provide dead tight shutoff of 35 psi (2,5 kg/cm<sup>2</sup>) maximum. Failure to isolate the lift station may cause pump damage and station flooding.

Discharge lines should be air-tight to prevent the liquid being pumped from entering the station or leaking into the surrounding ground. If gauges or other instruments are installed in the pump or piping, make certain that all connections are air-tight and sealed using "Loctite Pipe Sealant with Teflon" or equivalent compound.

Suction and discharge lines in the wet well are connected to piping in the station with 125 lb. flanges. Make certain that these mating flanges are squarely seated before tightening them; never pull piping into place by tightening connecting hardware.

#### Water Hammer Arrestor

In installations where the length, rise or profile of the force main may cause destructive hydraulic shock, a Water Hammer Arrestor should have been specified. The device will control these concus-

sions and prevent the rupturing of pumps, valves or piping.

If a Water Hammer Arrestor has been specified, make certain that it is installed and functioning properly before the lift station is placed in operation.



Air release lines or valves furnished with the lift station **are not** designed to act as shock arrestors, and are not intended as substitutions for proper control devices.

#### Air Bubbler Liquid Level Control Lines

If the station is equipped with an air bubbler liquid level control system, the air bubbler pipe should extend into the center of the wet well and terminate with a tee fitting. Where possible, position the tee fitting so that the cleanout extension will be accessible from the underside of the aluminum access doors and cap the pipe tightly.

Connect the bubbler pipe to the tee fitting. Connect the air bell to the bubbler pipe. Refer to the engineer's plans and specifications to determine the proper distance between the air bell and the floor of the wet well.



The air bubbler pipe and cleanout extension must be firmly supported and **absolutely airtight**.

#### ELECTRICAL SERVICE CONNECTION



The electrical power applied to this station is high enough to cause injury or death. Ground the station before applying line potential. Failure to do so may result in injury or death. A grounding electrode system must be available or installed and connected according to the National Electrical Code or local



**codes. Grounding electrodes are not furnished with this lift station.**

**This equipment contains more than one source of power. More than one disconnect is required to completely de-energize the lift station.**

Contact the electrical contractor for service extension to the control panel. Wiring must be made in accordance with the plans and specifications per local and the National Electrical Code. The schematic wiring diagram furnished with the station must be followed in making connections to the control panel.



On installations where a low voltage (115 volts) tap on incoming service is specified for control circuits and auxiliary equipment, care must be taken to ensure that the tap is not made to high voltage lines. If this occurs, **severe damage to control circuits will result**. The upper voltage limit for control power is 126 volts.

All electrical equipment in the lift station is grounded to the control panel sub-plate at the fac-

tory. Before applying line potential, however, ground the control panel itself at the main ground lug terminal installed on the control panel sub-plate.

The grounded circuit conductor, or one of the transformer secondary conductors (if supplied), is to be grounded if conditions permit. Follow practices recommended in the National Electrical Code or local codes.

Terminal blocks are provided for the power connections to the lift station. Refer to the schematic wiring diagram furnished with the station.

If a remote warning and/or alarm device is to be installed outside the lift station housing, install and connect the device.

### **FINAL INSTALLATION INSPECTION**

Ensure that all valves in the lift station are in the closed position as shipped from the factory.

Check that, where specified, a Water Hammer Arrestor has been installed, and that all pipes connected to the station are properly supported. Clean all construction debris from the wet well and pump station site area.

Verify that electrical service is properly connected.



All four eyes **must** be used. **Approximate maximum station weight – 8,600 lbs. (3900 kg.)**.

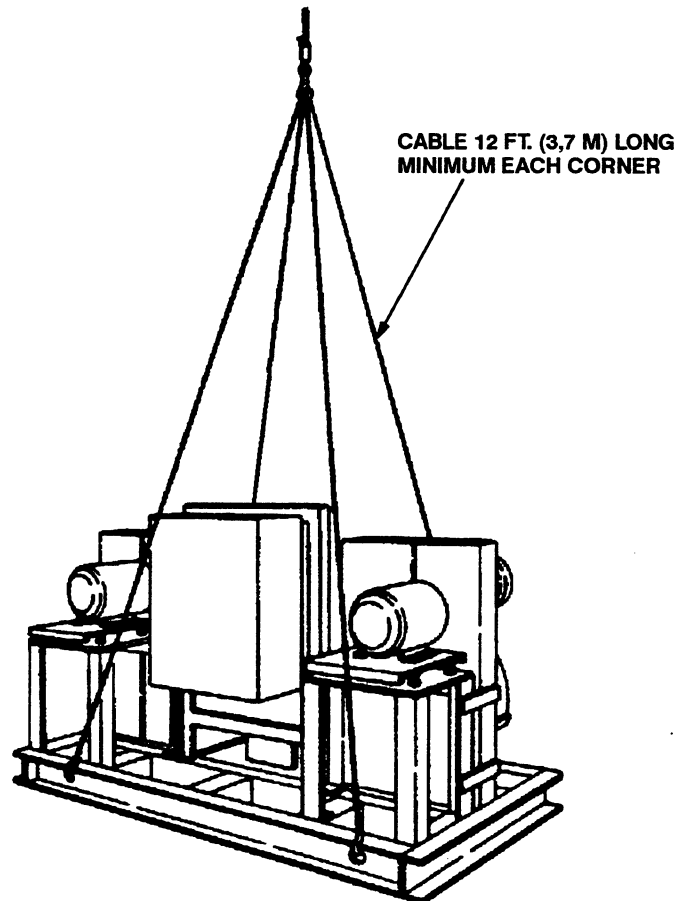

**NOTE**

*Avoid sudden starts and stops while moving station.*

Figure 2. Lifting Station With Slings

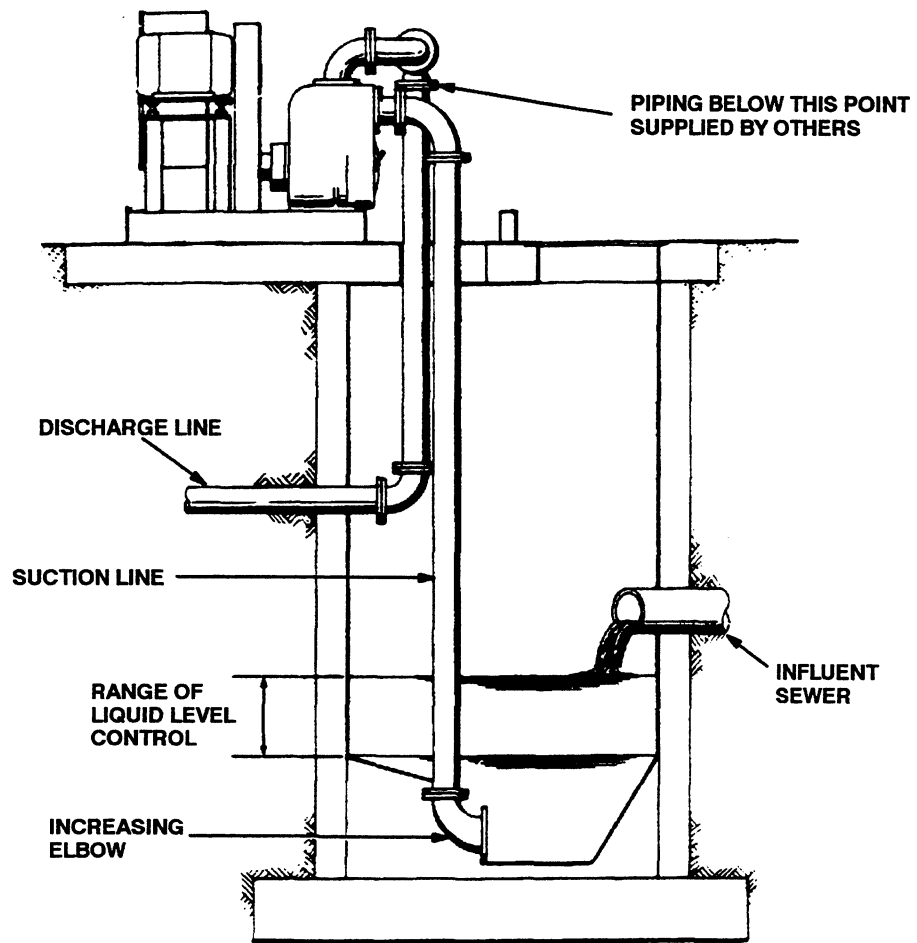

Figure 3. Typical Installation

## WARRANTY

Factory-built reinforced polyester lift stations manufactured by The Gorman-Rupp Company, Mansfield, Ohio are guaranteed to be of quality construction, free from defects in material and workmanship.

The pump station chamber and entrance tube shall be guaranteed for a period of ten (10) years to be completely resistant to rust, corrosion from moisture, corrosive soils, electrolysis or physical failures occurring in normal service, without protective coating or electrolysis preventive devices, when installation is made according to the manufacturer's recommendations.

The interior equipment, apparatus and parts furnished shall be guaranteed for a period of one (1) year, excepting only those items that are normally consumed in service, such as light bulbs, oil, grease, packing, gaskets, O-rings, etc. The lift station manufacturer shall be solely responsible for the guarantee of the station and all components.

The warranty will become effective upon the acceptance by the purchaser or the purchaser's authorized agent; or sixty (60) days after installation; or ninety (90) days after factory shipment, whichever occurs first.

Major components, such as station structure, pumps, pump motors, etc., failing to perform as specified by the engineers; or as represented by the manufacturer; or proven defective in service during the guarantee period, shall be replaced, repaired or satisfactorily modified by the manufacturer without cost of parts or labor to the owner. After start-up service has been performed, labor to replace necessary accessory items, such as dehumidifier, sump pump, blower, or any other accessible and easily serviced parts, shall be the responsibility of others. Such components, parts or repairs determined by the manufacturer to have failed because of defective workmanship or materials will be replaced or repaired, f.o.b. factory or other designated location.

It is not intended that the manufacturer assume liability for consequential damages or contingent liabilities arising out of the failure of any product or parts thereof to operate properly, however caused by or resulting from or arising out of defects in design or manufacture, delays in delivery, replacement, or otherwise.

THE GORMAN-RUPP COMPANY  
Mansfield, Ohio

**THE GORMAN-RUPP COMPANY • MANSFIELD, OHIO**

GORMAN-RUPP OF CANADA LIMITED • ST. THOMAS, ONTARIO, CANADA Printed in

U.S.A.

©Copyright by the Gorman-Rupp Company