

4 INCH CHECK VALVE ASSEMBLY

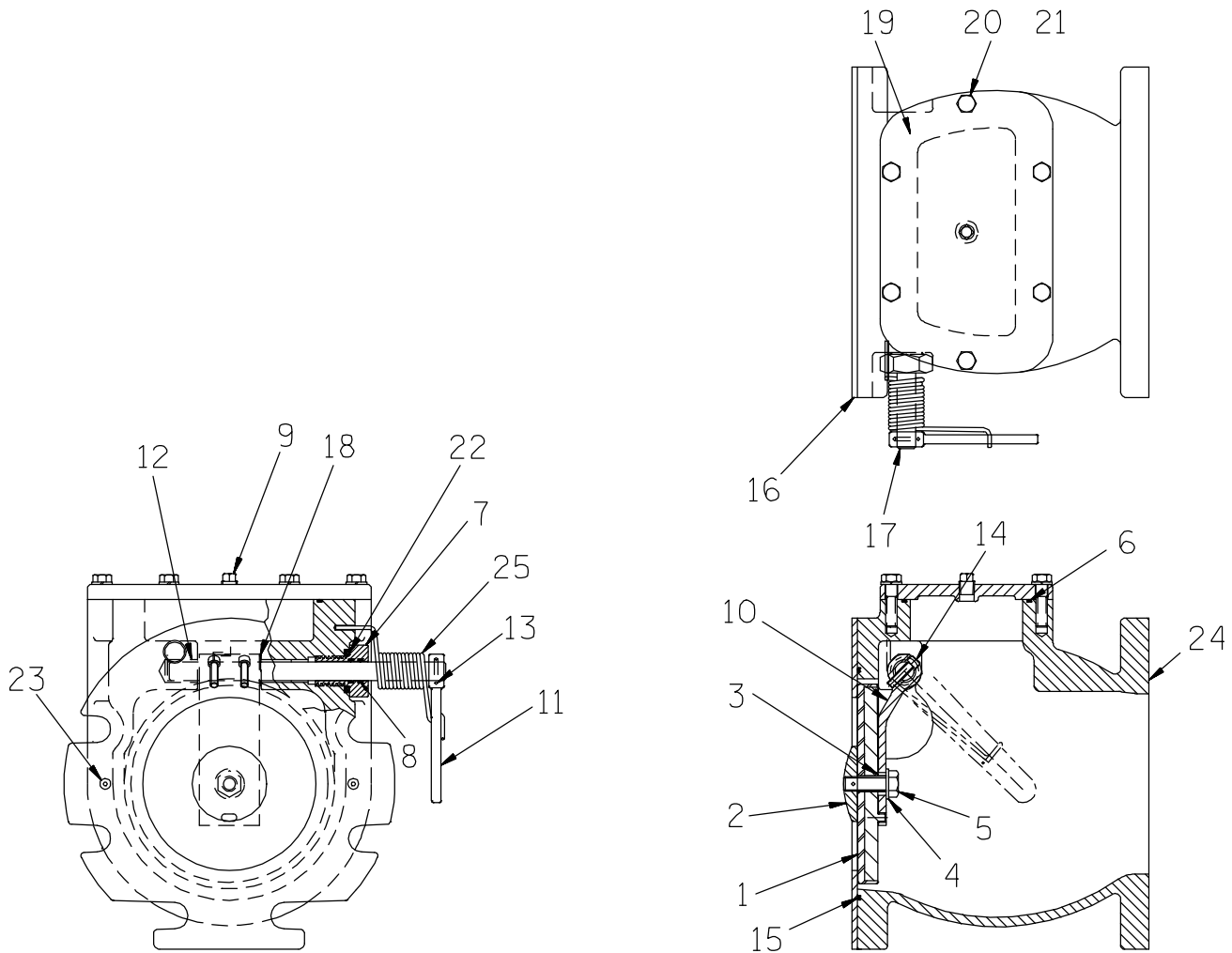

PARTS LIST

ITEM NO.	PART NAME	PART NUMBER	MAT'L CODE	QTY	ITEM NO.	PART NAME	PART NUMBER	MAT'L CODE	QTY
	4 IN CHK VLV ASSY-LH	46421-214	----	1	14	-SOC HD CAPSCREW	BD0404	17000	2
	4 IN CHK VLV ASSY-RH	46421-215	----	1	15	-O-RING	25152-162	----	1
1	-MOLDED CHK VLV	46411-131	24010	1	16	-CHECK VALVE SEAT	31265-067	17040	1
2	-VALVE WEIGHT	11588	10010	1	17	-SHAFT	31671-005	17010	1
3	-BUSHING	31143-148	17000	1	18	-SHIM	513A-3	17090	4
4	-FLAT WASHER	KE08	17000	1	19	-VALVE ACCESS CVR	38346-014	10000	1
5	-NYLOCK CAPSCRW	BT0806	17000	1	20	-HEX HD CAPSCREW	B0606	15991	6
6	-O-RING	25152-160	----	1	21	-LOCK WASHER	J06	15991	6
7	-SHAFT NUT	31871-072	14100	1	22	-O-RING	25152-318	----	1
8	-O-RING	25152-114	----	2	23	-FLAT HD CAPSCREW	F#10-03	17000	2
9	-PIPE PLUG	P04	15079	1	24	-VALVE BODY - LH	38341-214	10000	1
10	-CHECK VALVE ARM	38122-001	17070	1		-VALVE BODY - RH	38341-215	----	1
11	-CHECK VLV HANDLE	38582-024	11010	1	25	-SPRING - LH	38572-004	17110	1
12	-BUSHING	23161-106	----	2		-SPRING - RH	38572-003	17110	1
13	-ROLL PIN	S984	----	1					