



## XR50 User's Guide

203 W. Morris St. Indianapolis, IN 46225  
Telephone 317-885-6330 • support@omnisite.com  
www.omnisite.com  
v. 2.0



## XR50 User's Guide

203 W. Morris St. Indianapolis, IN 46225  
Telephone 317-885-6330 • support@omnisite.com  
www.omnisite.com  
v. 2.0

## Limited Warranty

If it appears within one (1) year from the date of delivery to Purchaser that any products or component parts do not conform exactly to the specifications and physical dimensions referred to above, and the Purchaser, at its expense, returns the product or component parts to the Seller together with a report of defects, the Seller shall review the inspection report and inspect the items and shall authorize, at its option, either the repair or replacement of any non-conforming products or component parts, whether on warranty, contract of negligence, shall not in any case exceed the amount to be paid by the Seller in obtaining and repair or replacement of non-conforming products or component parts, and upon expiration of the warranty period, all liability of the Seller shall be terminated. This warranty does not cover damage due to acts of God (fire, flood, lightning, etc.) nor product misuse and accidental damage.

Seller shall not be liable for any injury, loss or damage direct or consequential arising out of the use or the ability to use the product. This warranty gives specific legal rights. You may have other rights that vary from state to state. Some states do not allow the exclusion or limitation or incidental or consequential damages, so that the above limitation of exclusion may not apply to you

**WARNING:** The individual user should take care to determine prior to use whether this device is suitable, adequate or safe for the use intended. Since individual applications are subject to great variation, the manufacturer makes no representation or warranty as to suitability or fitness of these devices for any specific application.

## NOTICE

INSPECT CONTENTS IMMEDIATELY  
AND FILE CLAIM WITH DELIVERING  
CARRIER FOR ANY DAMAGE

## SAVE THE BOX AND PACKING MATERIAL

YOU ARE RESPONSIBLE FOR DAMAGE TO YOUR  
UNIT IF RETURNED IMPROPERLY PACKED.

## General Safety Instructions

### *Safety Signal Words*

**Danger:** means if the safety information is not followed, someone will be seriously injured or killed.

**Warning:** means if the safety information is not followed, someone could be seriously injured or killed.

**Caution:** means if the safety information is not followed, someone may be seriously injured or killed.

- 1. To reduce the risk of fire or shock hazard, connect OmniSite RTU directly to a 120 VAC electrical circuit. Do not use extension cords for permanent installation.**
- 2. Cover of OmniSite RTU must be securely closed to prevent water damage and electrical shock.**
- 3. Never operate your OmniSite RTU while any part is missing or damaged in any manner.**
- 4. To reduce the risk of electrical hazard or damage, do not tilt, jolt or tip RTU while unit is powered-on.**
- 5. To reduce the risk of accidental electrical shock, do not touch the electrical terminals or controls with wet hands.**
- 6. Note the warning label shown below.**

**WARNING: To reduce risk of fire, electric shock, or injuries always disconnect all sources of electrical power before servicing or cleaning.**

## Introduction

Congratulations - you just bought the best. The OmniSite system provides two-way communications using our patented WINGS™ (Wireless Information Network Gateway Standard) over a cellular network. The low cost of the OmniSite method makes remote monitoring very affordable, and allows our devices to operate on GSM networks worldwide. We have the most complete coverage and best reputation in the industry.

OmniSite wireless monitoring devices provide a low cost wireless system for remote monitoring, measurement, and data collection anywhere wherever there is GSM service, Worldwide.

## Overview

The OmniSite XR50 is a 10-channel monitoring device that has been optimized for use by the water and wastewater utilities. It is designed for indoor or outdoor environments, and operates from 120VAC or +15-20 VDC solar panels and

power supplies. The module's internal cellular modem module provides two-way communications through the fully automated OmniSite operations center to the www.OmniSite.com web site.

The standard operating program of the RTU monitors all (10) digital inputs and reports any changes. This information is immediately displayed on the web site, and user selectable alarm notifications for critical events can be sent via pager, e-mail, telephone call or any combination thereof. In addition, equipment status reports can be time scheduled in advance or requested at any time.

## Installation and Operation is Very Simple:

**Please note that your OmniSite product is a cellular device.** No matter how good the installation looks, without cellular reception, your device will not work! Therefore, your first step is to determine that suitable cellular service is available at the installation location BEFORE you start your actual installation. Connect your OmniSite unit to a temporary extension cord, and plug it in at the installation location. Look at the cellular signal strength LED on the XR50. If it is GREEN, you have a good signal, and can proceed with installation. If NOT GREEN, call OmniSite at 317-885-6330 to determine that your cellular signal strength is suitable. Once this is verified you can move-on to installing your equipment with confidence.

**Observe good wiring practices** - **DO NOT MIX high and low voltage wiring** inside your pump control panel. This creates a situation where high voltage cables can “induce” false signals onto your low voltage OmniSite inputs.

OmniSite low voltage cables should be routed inside low voltage wiring duct in your existing control panels. If you are not sure if high & low voltages are mixed inside your panel, you can always “tie-wrap” your OmniSite sensor wires to the outside of the wiring duct. This technique still provides an attractive installation while providing suitable separation from high voltages.

**CAUTION** - If you mount your OmniSite RTU inside of your existing electrical cabinet, then take extra care to **ensure that the antenna coaxial cable is NOT routed with high voltage cables or alarm horn power wires.** This can lead to unpredictable cellular reception or damage to the radio circuitry.

**OmniSite RTU's can be mounted indoors or outdoors** OmniSite's cellular devices can be mounted directly outdoors (if you purchased the NEMA 4X polycarbonate enclosure option), or inside of your existing electrical control panel if room allows. A common installation technique is to mount the RTU inside the existing electric control panel you are monitoring; mount our “Phantom” antenna on top of your existing panel; then connect the antenna to the RTU using an OmniSite supplied coax jumper cable. **Note that your antenna must be mounted outside of any metal electrical enclosure**

**Little Known Fact about Solar Power:** If you are planning on using a solar array to power the XR50, this will obviously have an impact on your installation location. A solar array must have unobstructed sunlight during the day, which means it cannot be partially covered by a leaf shadow, or shadow of any kind. Solar arrays are wired in series, and if any part of it is in a shadow, then the entire array is dead (i.e. not put-

ting out much, if any, power). Therefore, pick your solar panel location wisely, and face it to the south at a 45 degree angle. Also, if you are using solar power you will need to configure the XR50 unit to use its low power mode. The default mode is for the cellular radio to remain powered on at all times when power is applied to the XR50 to allow remote control from the web site. In low power mode, the radio is powered off after 1 minute of inactivity (*see how to set low-power-mode in "Appendix A"*)

**STEP (1) Connect the OmniSite XR50 to the equipment to be monitored using the wiring diagrams in this manual and turn it on. The monitor will automatically establish 2 way communications over the public cellular network to the [www.OmniSite.com](http://www.OmniSite.com) web site.**

## STEP (2) Using the Local Display and Keypad

We have good news for you. If you have physically connected your field wires according to STEP-1 using the wiring diagrams in this manual, and you are using the XR50 to merely monitor alarms, and provide pump runtime and on/off cycle information, then there are not any parameters that you have to set with the local display and keypad. The XR50 default settings have been optimized for a typical sewage lift station at our factory, and it is going to work as such.

However, the XR50 does have some "neat" software features, available through the local display and keypad. If you are interested in getting "more" out of your new XR50 product, then refer to APPENDIX A - LOCAL PROGRAMMING

## STEP (3) Configuring Your Equipment on the OmniSite Website

Once your installation is complete, configuring your equipment on the OmniSite website is easy:

- This is a cellular device like a telephone, and has an associated monthly cellular service fee. **YOU MUST** contact OmniSite at 317-885-6330 with your billing information or this unit will not transmit alarms. We will activate the cellular service and provide the User ID and Password you will use to sign-on to your secure web pages.
- Sign-on to the OmniSite website at [www.omnisite.com](http://www.omnisite.com) using your newly selected User ID and Password.
- Once signed-on select "Setup" and then "Callout list" and also "Device Setup".
- Follow the steps on the screen to complete the alarm message delivery. OmniSite devices can automatically send emails, text messages and voice calls in any sequence in response to an alarm event. These features are configured using the website interface.
- Helpful hint - If you get stumped use the "Help" link that is at the top of each page. It has very specific information as to how to fill-out the form you are currently working-on.
- **Don't like computers? No problem. OmniSite will setup your alarm message deliveries for a small fee. Simply call us at 317-885-6330. We will do the setup for you.**



# Wiring Diagrams - Cont'd

## Monitoring a Typical Pump Control Panel

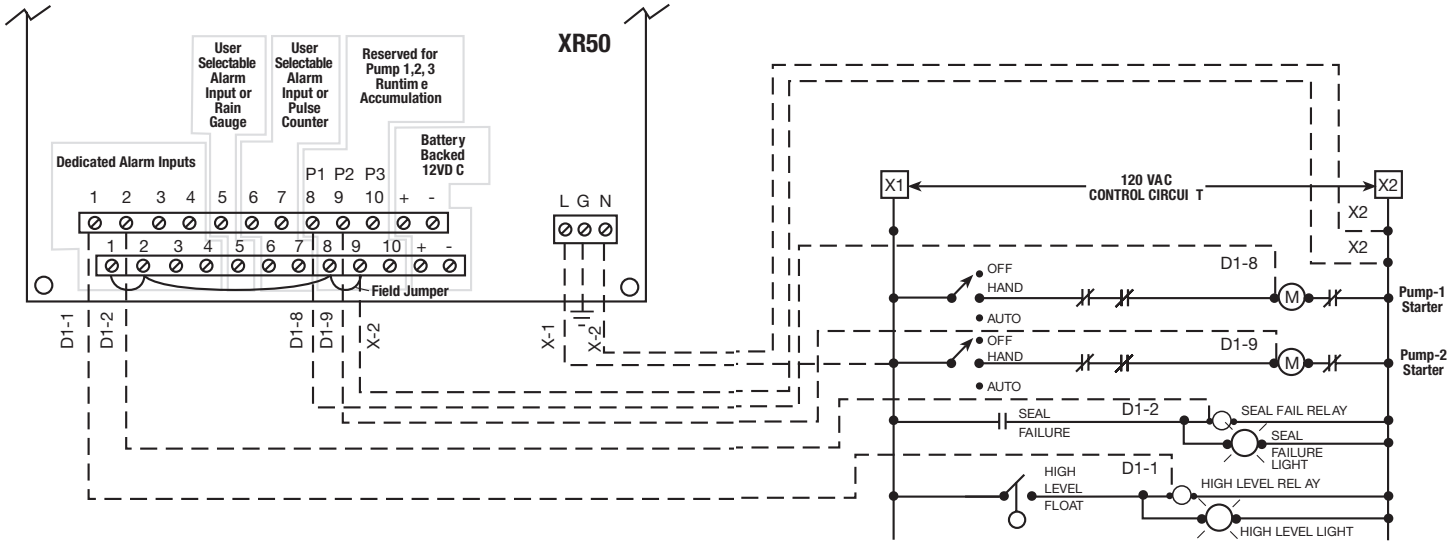

## XR50 Field Input Circuit Functionality

INPUT	DESCRIPTION
(Inputs 1 thru 4)	Connection of any "ON/OFF style" voltage signal in the range of 12VDC or 12 VAC thru 120 VAC or 120 VDC can be connected directly to these input circuits to monitor alarm signals (pilot lights, relays, coils, etc). No polarity has to be observed on these inputs, and different inputs can have different polarities/voltages. All alarm inputs have user adjustable alarm time delays adjustable thru the local display/keypad.
(Input 5)	Connection of any "ON/OFF style" voltage signal in the range of 12VDC or 12 VAC thru 120 VAC or 120 VDC can be connected directly to this input circuit to monitor alarms (pilot lights, relays, coils, etc). No polarity has to be observed on this input. All alarm inputs have user adjustable alarm time delays adjustable thru the local display/keypad. Alternatively, this input can monitor and totalize pulses from a rain gauge (used to plot rainfall vs. well inflow rate)
(Inputs 6 and 7)	Connection of any "ON/OFF style" voltage signal in the range of 12VDC or 12 VAC thru 120 VAC or 120 VDC can be connected directly to these input circuits to monitor alarms (pilot lights,

(Inputs 8 thru 10)

relays, coils, etc). No polarity has to be observed on these inputs. All alarm inputs have user adjustable alarm time delays adjustable thru the local display/keypad. Alternatively, these inputs can monitor and totalize pulses from a pulse output device at a max. rate of 30Hz (used to read flow and electric meters)

These inputs are reserved to monitor the coil or auxiliary contacts from Pump-1,2, and 3 motor starters. Connection of any "ON/OFF style" voltage signal in the range of 12VDC or 12 VAC thru 120 VAC or 120 VDC can be connected directly to these input circuits to monitor the pump run status. No polarity has to be observed on these inputs. These inputs provide daily reports of Pump-1,2,3 on/off cycles, total runtime, and GPM using timed draw downs on the well, as well as total station flow without the need for a flow meter. (Note: Flow calculations DO NOT work on stations using variable speed drives, and note that inputs 8,9,10 must be used with normally open contacts to correctly accumulate runtime (e.g. voltage is applied to input 8,9, or 10 when the respective pump is running)

(+ and - Terms)

These terminals supply a continuous, battery backed 12 VDC to any dry un-powered contacts providing alarm monitoring in the absence of AC power



## Appendix A - Local Programming

### Easily navigate the XR50 display as follows:

- 4-button interface. Buttons will be UP, DOWN, ENT, EXIT.
- Display is 2x16.
 

UP	DOWN	ENTER	EXIT
----	------	-------	------
- While working through menu structure:
  - Pressing UP or DOWN will select the next or previous menu item in the list. To select that item, press ENTER.
  - Pressing and holding EXIT for 2 seconds will return the user to the main menu.
  - Pressing and releasing EXIT will return the user to the previous menu.
- While editing a value:
  - If the value is numeric, the cursor will blink on the digit being edited.
  - UP and DOWN will be used to scroll through lists and increment and decrement numeric digits.
  - EXIT will cancel any editing WITHOUT saving the changes.
  - ENTER will move the cursor to the next position. If currently editing the last position or a list value, the value will be saved and the user returns to the menu mode.

**NOTE: The XR50 RTU must be disabled with the Intelligent ID key before setup changes can be made. When finished with setup, again use your Intelligent ID key to put the XR50 RTU back into service.**

## XR50 Menu Tree

- 1) Need Help?
  - Call OmniSite Ph. 317-885-6330
  - Or visit us online [www.omnisite.com](http://www.omnisite.com)
- 2) View Inputs
  - 1) Input 1 (ON/OFF)
  - 2) Input 2 (ON/OFF)
  - 3) Input 3 (ON/OFF)
  - 4) Input 4 (ON/OFF)
  - 5) Input 5 (ON/OFF)
  - 6) Input 6 (ON/OFF)
  - 7) Input 7 (ON/OFF)
  - 8) Pump 1 (ON/OFF)
  - 9) Pump 2 (ON/OFF)
  - 10) Pump 3 (ON/OFF)
  - 11) Rain Pulses: (---/0-99)
  - 12) Counter-1: (---/0-9999)
  - 13) Counter-2 (---/0-9999)
  - 14) P1 GPM: (0-2000)
  - 15) P1 Runtime: (hrs:mins)
  - 16) P1 Starts: (0-999)
  - 17) P1 Drawdwn: (hrs:mins)
  - 18) P2 GPM: (0-2000)
  - 19) P2 Runtime: (hrs:mins)
  - 20) P2 Starts: (0-999)
  - 21) P2 Drawdwn: (hrs:mins)
  - 22) P3 GPM: (0-2000)
  - 23) P3 Runtime: (hrs:mins)
  - 24) P3 Starts: (0-999)
  - 25) P3 Drawdwn: (hrs:mins)
  - 26) Well Fill: (mins:secs)
  - 27) Inflow Rate: (0-99999)

**Key:** (range or options; default)

**View Inputs:** Use this menu option to view all connected equipment and operational status since the RTU last reported to your web page.

## XR50 Menu Tree

### 3) Enter setup

**Enter Setup:** Use this option to make any desired field settings. The most frequently changed settings are as follows:

- **Input alarm time delays -**

For each alarm, define the alarm and the alarm time delay (i.e. the amount of time the input must remain in that position before a call is made).

- **Make an input a counter or rain gauge -**

Inputs 5,6,7 can be converted to totalize pulses from any pulsing device like flow meter, rain gauge, electric meter, etc.

- **Set RTU Date & Time -** If you want your reports to come in at a specific time each day, then make sure the correct time/date are set. If you do not set the time/date the reports will still arrive once every 24 hours.

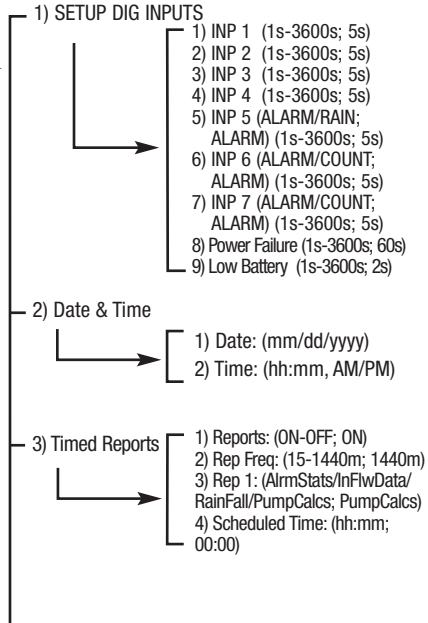

### 3) Enter setup (cont'd)

#### 4) Pump GPM Calcs

- 1) P1 GPM (0-2000)
- 2) P2 GPM (0-2000)
- 3) P3 GPM (0-2000)

#### 2) Tank Shape

- 1) Cylinder xxx
- 2) Rectangle xxx

- 1) Decimal Pos. (xxx,xx.x,x.xx; xxx)
- 2) Stop-Lead (0-999ft; 0)
- 3) Diameter (0-999ft; 0)
- 4) Lead Vol. (0-99999g)

- 1) Decimal Pos (xxx, xx.x, x.xx;xxx)
- 2) Stop-Lead (0-999ft; 0)
- 3) Width (0-999ft; 0)
- 4) Length (0-999ft; 0)
- 5) Lead Vol. (0-99999g)

#### 5) SD DATA LOG

- 1) Trend Log (ON/OFF; OFF)
- 2) Sample Rate (0-720 min; 2min)

**Enter Pump GPM Rating and Well size -** You have to answer these questions if you want the XR50 to calculate station flow, and calculate pump GPM rate.

## XR50 Menu Tree

### 4) Diagnostics

**Diagnostics** - This section is reserved for OmniSite trained field service personnel. Call OmniSite at 317-885-6330 with questions about this section.

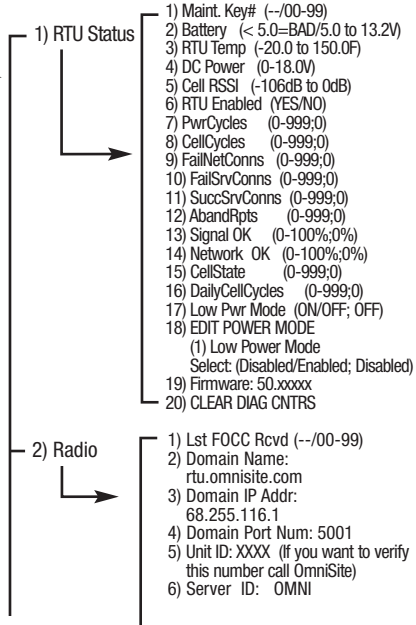

### 4) Diagnostics (cont'd)

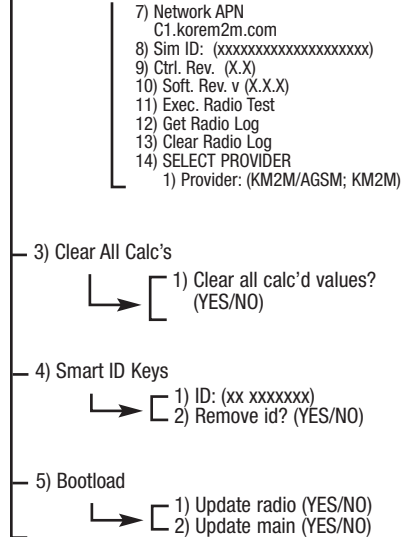

## Appendix B - Hardware Specification

### Specifications:

Power Supply	80-265 VAC +/-10% or 15-20 VDC +/-10%
Max. Power Consumption	0.3 amps @ 120 VAC or 2.1 amps @15 VDC
DI Inputs	(10) universal input 12VDC/VAC thru 120 VDC/VAC +/-10%
Counter Inputs	(2) avail. At 30Hz max. Freq
Rain Gauge Input	(1) Avail for pulse only. Each pulse must = 0.01" rain
Operating Temp.	-20 to 150 F
Storage Temp.	-20 to 180 F
Humidity	5-95% RH, non-condensing
Enclosure	Weatherproof, equivalent to NEMA 4X (Optional)
Terminals	Removable, spring clamp style
Weight	5.6 lbs.
Communications	Local RS232 Port
Memory Type	EEPROM, Flash
Isolation Voltage	4000 VAC opto-isolated
Input Impedance	10Kohm min.
Surge	ANSI C37.90.1
Dimensions	8.25w x 8.6h x 2.75d
Aux. Power Out	100 mA @ 12 VDC
Battery Charger	15 VDC capable of charging 800 mA AH -17 AH gell cell

System Key Switch	Smart Key, 100 Million combinations
Radio Frequency	4G LTE CAT-1
Antenna	850/900/1800/1900 MHZ, phantom style
Transmission Time	1-2 seconds, field-to-web page

## Appendix C - Repair Parts

In the unlikely event that you should have a problem with your new OmniSite product, the following replacement parts are available for purchase from OmniSite. Note that the printed circuit boards (PCB), themselves, are not a field repairable part. If you have a problem with an OmniSite printed circuit board, the repair consists of replacing the entire (PCB) unit. Contact your OmniSite distributor for details.

Part Number	Description
BATTI208	Rechargeable 800 mA gel cell battery
KE	"Crew on-site" replacement key
EN	XR-50 Weatherproof enclosure

\*- All items are typically "in-stock" for immediate delivery

- For the repair or replacement parts you need call (317) 885-6330 between 8 am - 5 pm, Monday - Friday Eastern Daylight Time.

- For on-site repair service 24 hours a day, 7 days a week contact your local OmniSite distributor in your area.
- For the location of an OmniSite repair service center in your area call OmniSite at 317-885-6330.
- For information on purchasing an OmniSite Maintenance Agreement or to inquire about an existing Agreement call (317) 885-6330 between 8 am - 5 pm, Monday - Friday Eastern Daylight Time.
- The model number will be found on the OmniSite identification label.
- When requesting service or ordering parts, always provide the following information: Serial number, model number and part description.

## Appendix D - Troubleshooting Chart

Trouble	Probable Cause	Remedy
Unit does not transmit alarms, and no control panel lights are illuminated.	No Power	Check 120 VAC or 12 VDC power source.
Unit does not transmit alarms and power source is present	Cellular signal reception is not suitable	Inspect the cellular signal strength LED on the face of the XR50. If it is not GREEN, then you MAY have a weak signal. Call OmniSite at 317-885-6330.  We will observe the transmitted signal strength suggest options for you, which may include replacing the antenna or relocating the antenna.
My field alarm contacts open and close, but the OmniSite unit does not appear to be doing anything.	Wiring problem or contacts have not remained open or closed for at least 5 seconds	The OmniSite RTU will transmit an alarm signal if, it changes "state" and remains in that "state" for at least 5 seconds. Note - this is a user adjustable time delay, and may be longer for your application. Next - disconnect the field wires from the RTU for the alarm input in question. Using a volt-ohm

Trouble	Probable Cause	Remedy
(Con't)	(Con't)	<p>meter, determine that your contacts are actually opening and closing. If not, make field repair.</p> <p>If they are, check on the XR50 front panel to see that the associated LED goes on/off as your field signal changes. Lastly, visit the OmniSite website to confirm that you have an associated alarm trigger and a call out list specified for the event.</p>
<p>My pump runtime readings are not automatically updating on the OmniSite website</p>	<p>Time Scheduled reports are not enabled</p>	<p>The OmniSite RTU reports pump runtimes and other values on time scheduled intervals (typically once/day). You must manually "enable" this feature from the OmniSite website. Additionally, you can manually request the pump runtime values at any time by visiting the OmniSite website and issuing the appropriate command.</p>

Trouble	Probable Cause	Remedy
<p>The OmniSite units keeps calling me with alarms, and when I visit the site, I can not find any problems.</p>	<p>OmniSite RTU is receiving "false" alarms.</p>	<p>Your OmniSite RTU is a sophisticated piece of electronic monitoring equipment. It is only "as good" as the equipment it is monitoring. In other words, if your control panel is issuing "false" alarms, the OmniSite RTU WILL REPORT them. Contact your local OmniSite distributor to locate causes for "false" alarms from your equipment, or increase alarm time delays to eliminate "false" alarms.</p>

## Appendix E - Location for Setting Software Parameters

Process	Unit	Web Site
Enter input time delays	√	
Enter wet well dimensions	√	
Enter datalogging parameters	√	
View current pump calculations & counter readings	√	√
View current digital input status	√	√
Setup GPM override		√
Setup recipient email, phone and text information		√
Setup call-out list order and delays		√
Setup alarm state for inputs		√
Setup notification events		√
View charts, graphs and export data		√
View logs and history		√
Analyze inflow and rainfall		√

## NOTES

---



---



---



---



---



---



---



---



---



---



---



---



---



---



---



---

